

QUALITY & SERVICE SINCE 1954  
**FRED C. GILBERT CO.**  
 LIQUID HANDLING EQUIPMENT  
 LUBRICATOR & METERING PUMP SERVICE CENTER  
 1615 'A' BEDFORD WAY BAKERSFIELD, CA 93308  
 805-399-9569 <http://www.fcgilbert.com>

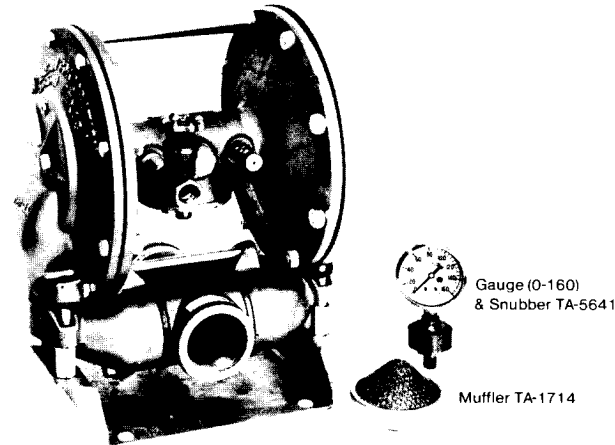

**TEXSTEAM INC.**  
**SERIES 9000**

# Pump Catalog & Parts List



OPTIONAL EXTRAS

Gauge (0-160) & Snubber TA-5641

Muffler TA-1714

## AIR OR GAS DRIVEN DOUBLE DIAPHRAGM UTILITY PUMP

### DESCRIPTION

The Series 9000 Double Diaphragm Utility Pump is a double acting, positive displacement pump operated on either air or gas. A range of operating power pressures from 5 to 100 psi provide discharge volumes up to 60 gallons of water and discharge pressures up to 60 psi through 2" suction and discharge ports.

It handles any liquid from alcohol to mud, liquids containing solids 1/4" in diameter with ease and liquids containing abrasives with a minimum of wear.

The 9000 can operate completely submerged. It is smokeless, quiet, fireproof and needs no priming for suction lifts up to 14 feet of water, and up to 23 feet primed.

#### Models Available

- 9001 — Can be used for all normal services
- 9002 — Equipped with ball check valves for handling viscous, fibrous materials. Reduce pumping capacities shown by 10% when using the 9002.

### SPECIFICATIONS

<i>Maximum Power Gas Pressure</i> .....	100 psi	<i>Maximum Fluid Suction Lift</i> .....	23 ft. water (primed)
<i>Max. Recommended Gas Exhaust Bk. Press.</i> ...	20 psi	<i>Max. Recommended Fluid Capacity</i> .....	60 gpm
<i>Minimum Power Gas Pressure</i> .....	5 psi	<i>Min. Recommended Fluid Capacity</i> .....	1 gpm
<i>Max. Recommended Gas Consumption</i> .....	50 cfm	<i>Max. Recommended Strokes/Min.</i> .....	250 spm
<i>Max. Recommended Fluid Discharge Press.</i> ....	60 psi	<i>Power Gas Safety Valve Set at</i> .....	125 psi
<i>Max. Temperature: Standard Trim</i> .....	200°F	<i>Weight</i> .....	70 lbs.
<i>Teflon Trim</i> .....	200°F		

# SERIES 9000

## TEXSTEAM'S ALL PURPOSE UTILITY PUMP

### WHAT IT'S BEING USED FOR?



#### PUMPING SLURRY

for ceramic tile manufacturer as part of a permanent plant installation.



#### RECIRCULATING

crude oil through a treater installation for a producer in West Texas.



#### PUMPING BILGE WATER

out of the hold of ships and barges along the Louisiana coast.



#### FIGHTING FIRES

along a ship channel where gasoline storage requires explosion-proof pumping equipment.



#### TRANSFERRING FUEL

for a drilling rig in the Gulf of Mexico where existing laws discourage contamination of the water.



#### IMPARTING TURBULENCE

necessary for proper mixture while pumping solutions for an eastern chemical firm.



#### PROPORTIONING CHEMICALS

in a system utilizing electric timers and flow meter equipment in the Great Lakes Region.



#### CLEANING SUMP PITS

for a truck transport company in their cleaning and maintenance shop.

### PERFORMANCE OF TEXSTEAM DOUBLE DIAPHRAGM PUMP MODEL 9001 \*

#### GAS PRESSURE NEEDED TO DRIVE PUMP - GIVEN IN PSI

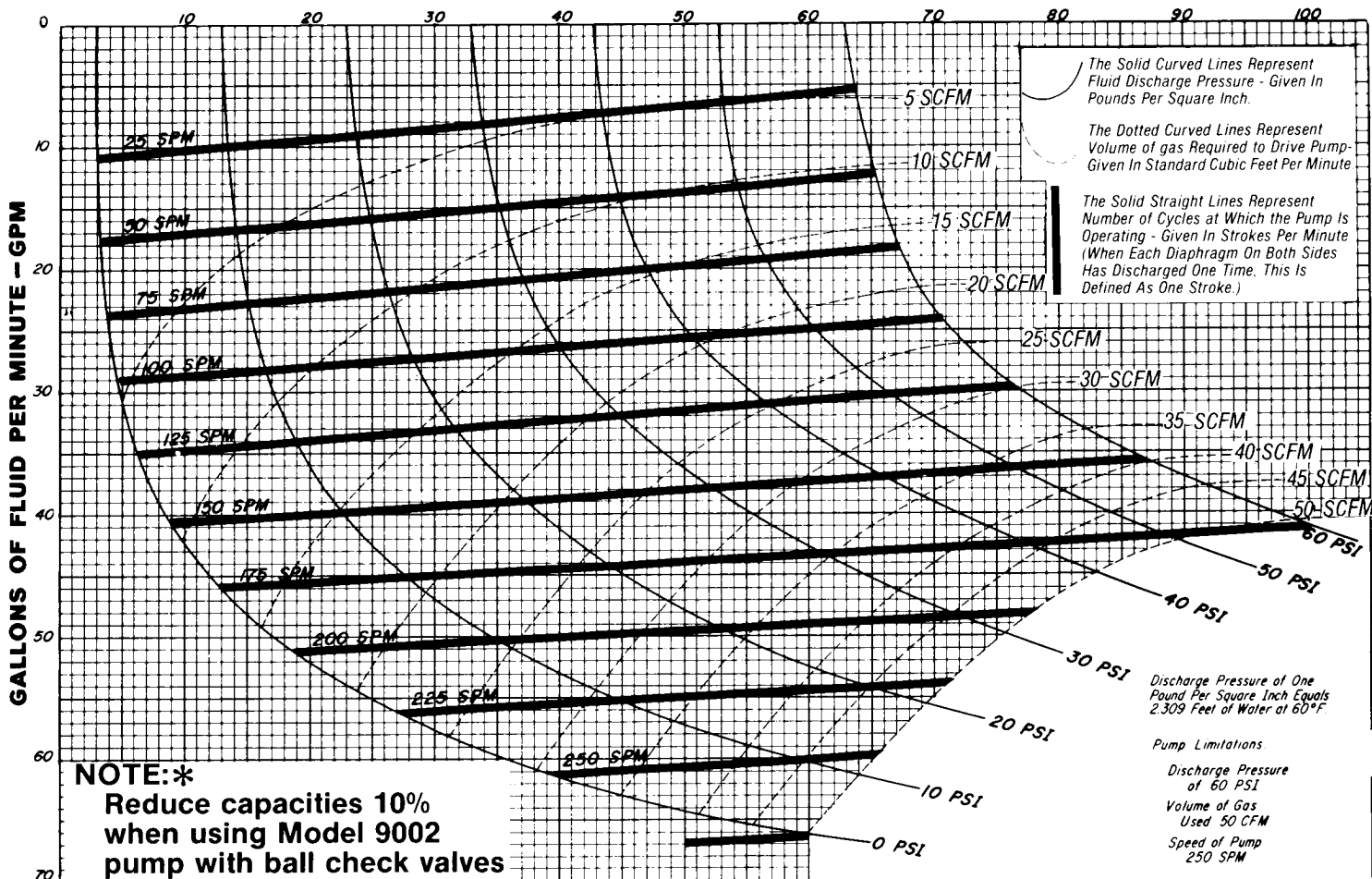

## INSTALLATION

The gas control valve (Item 37), supplied with the Series 9000 pump, has a  $\frac{1}{2}$ " NPT female connection. Before attaching the power supply line to this valve, **BLOW THE SUPPLY LINE OUT TO REMOVE ALL FOREIGN PARTICLES.** With a power supply available, the pump will begin operation immediately when the control valve is opened.

### Power Supply Lines

Air or gas supply lines should be sized to assure a sufficient power supply for maximum desired pump operation. Volumes and pressures are easily determined on the attached performance chart. Power pressure requirements indicated on the chart are measured at the pump. **KEEP SUPPLY LINE PRESSURE DROP IN MIND WHEN SIZING THE LINE.** For convenience, a pressure gauge port is provided on the power intake housing. The  $\frac{1}{4}$ " plug (Item 55) may be removed and a dampened pressure gauge (Alternate Item 58), available at slight additional cost, installed. Although the complete pump housing is hydrostatically tested to 100 psi, **FOR OPTIMUM OPERATION, POWER SUPPLY PRESSURE AT THE PUMP SHOULD NOT EXCEED 100 PSI.**

### Power Exhaust

If exhaust air or gas is to be released to atmosphere, it will pass through a  $\frac{3}{8}$ " NPT nipple (Item 54) which acts as a thread protector for female connection in the exhaust manifold (Item 12). When extra-quiet operation is required, the nipple (Item 54) may be removed and a small muffler (Alternate Item 57) may be installed.

If exhaust air or gas is to be piped away, connection may be made to  $\frac{3}{8}$ " NPT nipple (Item 54). Should female connection be required, remove nipple and connect exhaust line directly to  $\frac{3}{8}$ " NPT female connection in the exhaust manifold (Item 12).

In planning exhaust line, **BE SURE NOT TO UNDER-SIZE THE LINE.** Excessive back pressure will reduce pump efficiency.

### Pumped Liquid

Both suction and discharge ports on the liquid manifold (Item 39) are 2" NPT. The suction connection is assembled on the same side of the pump as the power inlet control valve (Item 37). This is merely for convenience and may be reversed by reversing the position of the check valves.

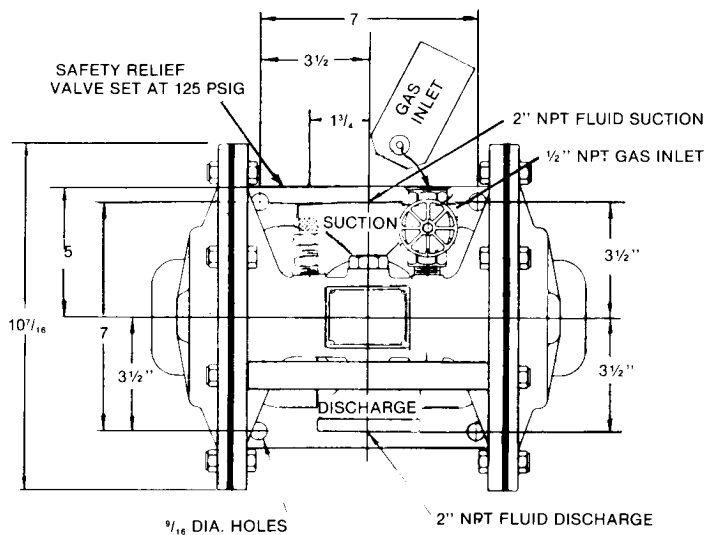

## Power Supply

It is extremely important that **POWER AIR OR GAS BE CLEAN AND FREE FROM FOREIGN PARTICLES.** For intermittent service, continuous lubrication of the power mechanism is not required. Occasional injection of a small quantity of quality lubricant (SAE 20) into the power gas supply is sufficient. However, for continuous service with unattended operation, a lubricator and filter (Accessory Items 57, 58, 60 & 61) are recommended. The lubricator should be set to add approximately 120 drops of oil per hour.

## MAINTENANCE

Tools required for complete assembly and disassembly:

\*Two crescent wrenches (one of which will span a 1" hex).

One medium size screwdriver (bit width approx. 5/16").

One drift or pin punch (point approx. 5/32" diameter).

Small hammer to drive punch.

Sharp pointed instrument for removal of retaining ring.

\* If crescent wrenches are not available, the following size open end wrenches will be needed: 1" - 3/4" - 11/16" - 9/16" - 1/2" - 1/4".

NOTE: Unless it becomes necessary to remove detent cage (Item 6) from the suction rod (Item 7), which will be a rare case, the punch, hammer, and sharp pointed instrument will not be needed. The majority of maintenance work will require only the two crescent wrenches and screwdriver.

If the pump runs but does not pump, shut off power supply and:

1. Remove check valve manifold (Item 39) and examine check valves.
2. Check suction line for restrictions or leaks where pump may be pulling in air instead of fluid.

If pump stalls or will not run:

1. Shut off power supply, and: remove detent assembly (Item 33) and check detent balls, detent ball stops and detent ball springs. Remove gas manifold (Item 12) and examine slide valve (Item 53).
2. Check air or gas supply line to see if pump is getting pressure.
3. Check fluid discharge pressure and be sure it is not equal to or greater than air or gas supply line pressure. Make certain discharge line is not restricted.

If preliminary checks fail, disassemble pump and examine.

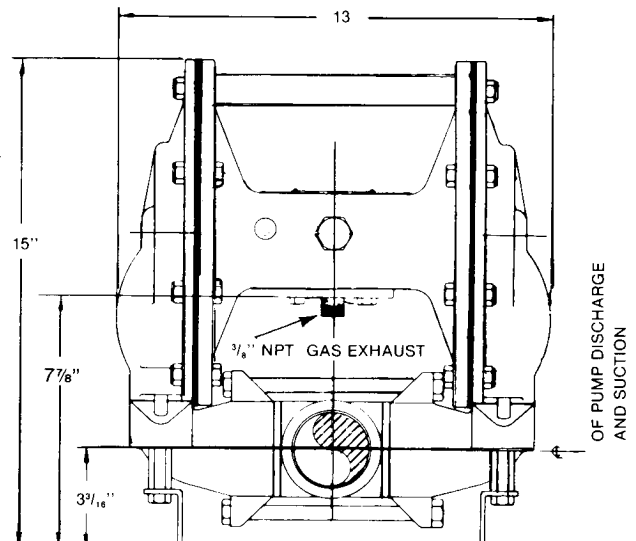

# PARTS LIST—9001

ITEM	DESCRIPTION	NO. REQ'D.	PART NO.
1	1/4" Cap Screw	6	TA-2502
2	Retainer	2	TB-638
3†	Packing - Leather	2	TB-651
4	Pin - SS	2	TA-1223
5	Body, Cast Iron	1	TD-389
6†	Cage - CS	1	TB-645
7†	Rod 174 Ph SS	1	TB-640
8	Washer - SS	2	TB-641
9	Nut	14	TA-439
10	3/8" Cap Screw	16	TA-5655
11	Gasket	1	TB-631
12	Exhaust Manifold	1	TB-626
13	1/16" Cap Screw	4	TA-2913
14	Nut	4	TA-2012
15	3/8" Cap Screw	4	TA-2501
16	Nut	2	TA-1294
17	Base, 10 ga. Galv.	1	TC-515
18	Pin	4	TA-1222
19	1/16" Cap Screw	2	TA-934
20	Adapter, C.I.	2	TC-507
21†	Gasket - Neoprene Std.	2	TB-636
	TFE, Optional	2	TA-2545
22	Outer Flange, C.I.	2	TC-485
23†	Diaphragm-Buna-N. Std.	2	TB-635
	TFE, Optional	2	TB-750
24	Nut	2	TA-1224
25	Plate	2	TB-642
26	Name Plate	1	GA-3184
27†	Ring	2	TA-1229
28†	Spring - 17-7 PH	1	TA-2189
29	Support - CS	2	TB-644
30	Safety Valve, Set 125	1	TA-1241
31	Pilot - CS	2	TB-643
32†	Bearing - Nylon	2	TA-1291
33†	Detent Assy. Kit	1	TA-3796
36†	Bail, 440 SS	2	TA-1292
37	Valve	1	TA-1309
38†	Seat Plate 410SS	2	TB-646
39	Manifold	1	TB-630
40†	Seat-Polyurethane Std.	4	TA-1986
	Teflon, Optional	4	TA-2547
41†	Disc	4	TA-1985
42†	Nut	4	TA-1306
43†	Check Body 15-7SS	4	TB-647
44†	Spring 17-7 PH	4	TB-632
45†	Gasket, Neoprene	4	TB-628
	Teflon, Optional	4	TA-2546
46†	1/4" Cap Screw	4	TA-1305
47	Stud	4	TA-1299
48	Gland, C.S.	2	TB-639
50	Handle	1	TA-1958
51	1/2" Nipple	1	TA-2499
52	Drive Screw	4	TA-2497
53†	Slide Valve Phenolic	1	TB-627
54	3/8" Nipple	1	TA-2500
55	1/4" Plug	1	TA-138
56	1/8" Plug	2	TA-2220
*Optional Items			
*57	Muffler (in lieu of 54)	1	TA-1714
*58	Gage (in lieu of 55)	1	TA-1713
*59	Bleeder (in lieu of 56)	2	TA-2011

Not Shown: All late model pumps are equipped with two TA-2575 Slide Valve Guide Pins, assembled in Item #12 (TB-626).

†Recommended spare parts

For continuous and unattended service, the following accessories are recommended:

60	Lubricator (not shown)	1	TA-1857
61	Filter (not shown)	1	TA-1858

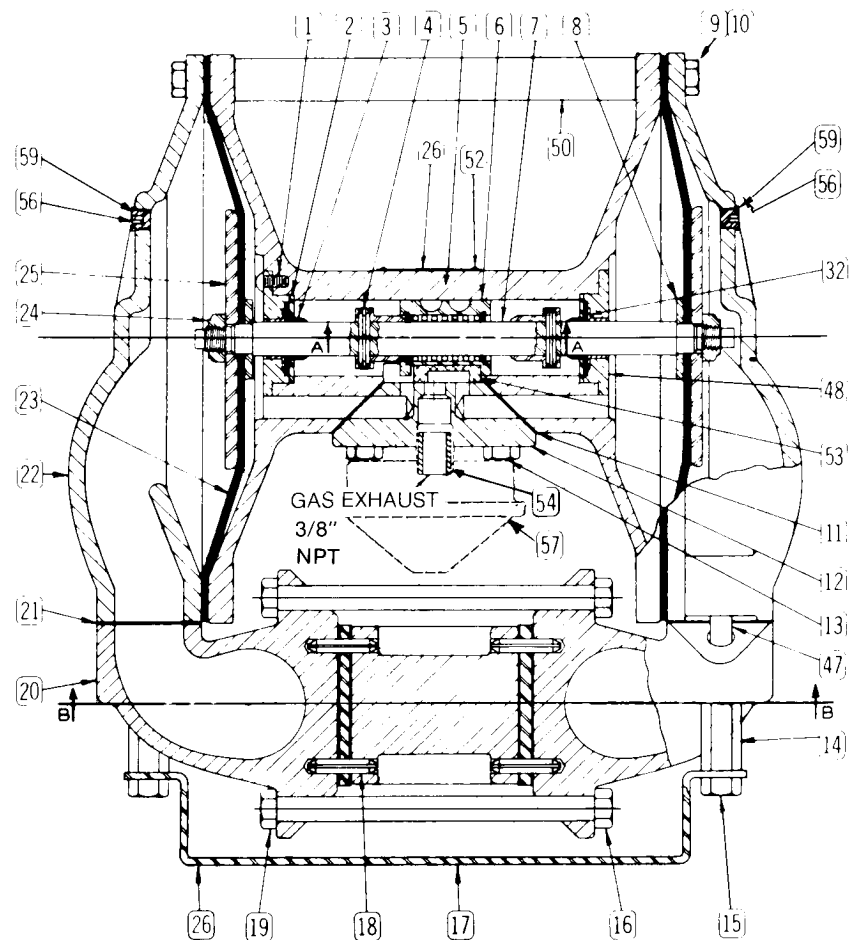

**ITEM 33**  
**Detent Spring Assembly, Kit No.**  
 Two of these assemblies are included in each kit.

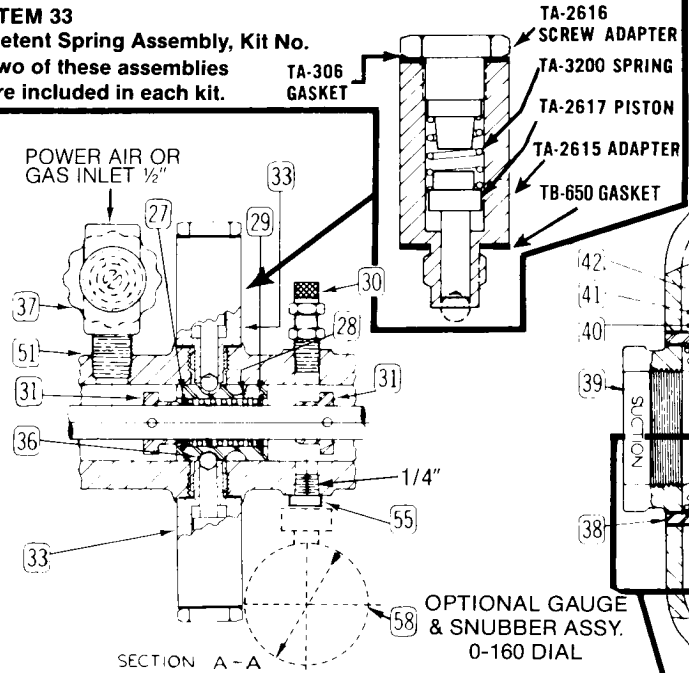

SECTION B - B

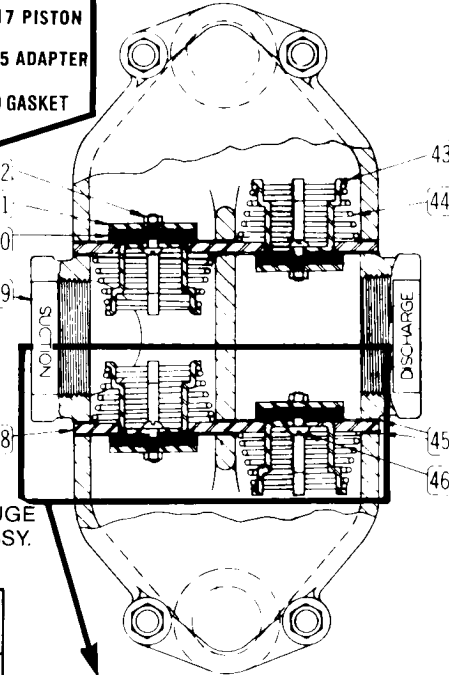

**ALTERNATE PARTS FOR MODEL 9002 (Ball Checks)**  
 (Pumps MUST be horizontal to operate)

ITEM	DESCRIPTION	NO. REQ'D.	PART NO.
20	Adapter (Left)	1	TC-287
20 A	Adapter (Right)	1	TC-288
38	Seat Plate (Left)	1	TB-520
38 A	Seat Plate (Right)	1	TB-521
41	Ball	4	TA-2026

Order Kit No. TB-652 for replacement of Suction and Discharge Valve Assemblies. 2 Kits required if all 4 valves need replacing.



TEXTEAM INC.