

TECHNICAL BULLETIN



SERIES

2200

CHEMICAL INJECTION PUMPS

PRODUCT FEATURES

- ◆ 1/4 horsepower motor is available in TENV or Explosion Proof, single or three phase
- ◆ Available in 12 volt DC
- ◆ The stroke adjustment is adjustable while running
- ◆ Fluid ends are 316 stainless steel
- ◆ Four plunger sizes are available; 3/16", 1/4", 3/8", and 1/2"
- ◆ The geared motor has a built in gear reducer available in 15, 30, 60 strokes per minute
- ◆ Maximum volume of 130 gallons per day (duplex model)
- ◆ Maximum discharge pressure 1,000 PSI
- ◆ Modular design allows easily interchangeable fluid ends
- ◆ Motors meet CSA and UL specifications
- ◆ Oil-less-requires minimal lubrication for long life
- ◆ Adjustable while running

OPTIONS

- ◆ Ceramic plungers which provide longer packing life



MODEL DESIGNATION

22F4

PLUNGER SIZE

- 4 — 3/16"
- 1 — 1/4"
- 3 — 3/8"
- 5 — 1/2"

STROKE SPEED

- F — 60 SPM
- G — 30 SPM
- H — 15 SPM

2200 SERIES



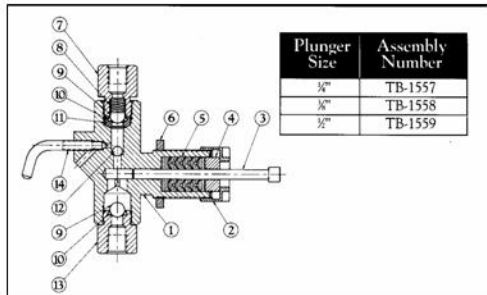
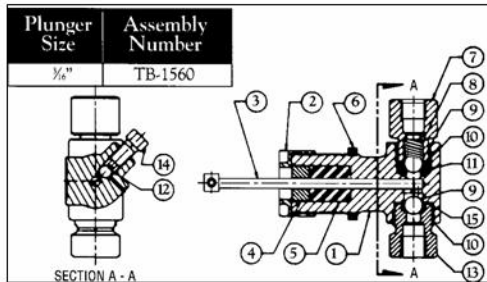

Injector Head Parts List

Item	Description	Material	Part Number			
			1/8"	3/16"	1/4"	1/2"
1	Body	SS	TC 2040	TC 0291	TC 0425	TB 0349
2	Gland Nut	303 SS	TA 4104	TA 4104	TA 4104	TA 4104
*3	Plunger	17-4PH	TA 6082	TA 6079	TA 6080	TA 6081
4	Gland	303-SS	TA 5642	TA 1463	TA 0957	TA 1219
*5	Plunger Packing**	Buna-N	TA 3969	TA 1461	TA 1456	TA 0959
		Hard	TA 3948	TA 2295	TA 1875	TA 1874
		Viton	TA 3967	TA 4102	TA 4101	TA 4103
		Teflon	TA 3966	TA 1642	TA 1234	TA 1012
*6	Lock Nut	Brass	TA 0225	TA 0225	TA 0225	TA 0225
7	Top Bushing	303-SS	TA 1496	TA 1496	TA 1496	TA 1496
*8	Ball Check Spring	316-SS	TA 0077	TA 0077	TA 0077	TA 0077
*9	Large Ball 1/8"	316-SS	TA 0054	TA 0054	TA 0054	TA 0054
*10	O-Ring	Buna-N	TA 0479	TA 0479	TA 0479	TA 0479
		Viton	TA 2093	TA 2093	TA 2093	TA 2093
11	Top Check Seat	303-SS	TB 0734	TB 0734	TB 0734	TB 0734
*12	Small Ball 1/4"	316-SS	TA 0126	TA 0126	TA 0126	TA 0126
13	Bottom Bushing	303-SS	TB 1213	TB 1213	TB 1213	TB 1213
14	Priming Valve	303-SS	TA 5462	TA 1497	TA 1497	TA 1497
15	Gasket	304-SS	TA 4394			

* Recommended Spare Parts

** See table back page

2200 Installation and Start-Up Instructions

INSTALLATION

PUMP LOCATION-AN IMPORTANT FACTOR

- ⇒ Plan ahead for proper pump mounting-position it to provide for efficient routing of suction and discharge lines, as well as electric service
- ⇒ Avoid long suction lines
- ⇒ Provide for a flooded suction line whenever possible
- ⇒ Pump fluid lines and connections operate best when there is a minimum restriction to the medium flow
- ⇒ Install the proper electrical starters and disconnect switches
- ⇒ It is recommended that a solid mounting support be provided—take advantage of the factory installed holes in the base plate for securing the pump

FLUID END

- ⇒ All fluid connections, both suction and discharge, should be seal tight. Fluid end connections are 1/2" NPT
- ⇒ The suction connection is at the bottom of the fluid end, and the discharge connection is at the top.

MOTOR

- ⇒ A conduit connection is provided at the motor for electrical connections.
- ⇒ Assure the proper electrical service has been provided
- ⇒ Assure all connections are tight, in their proper location, properly grounded, and fused

START UP

- ⇒ Open the priming valve on the fluid end assembly
- ⇒ Start the pump motor
- ⇒ Allow the pump to run until a clear stream of media comes out of the priming valve
- ⇒ Close the priming valve
- ⇒ Check the packing for proper sealing. If it leaks, stop the pump and make the necessary adjustments.
- ⇒ Adjust the stroke adjustment knob to obtain the desired flow rate.

PREVENTIVE MAINTENANCE

- ⇒ Check periodically (minimum once a month) and apply a small amount of grease to the cam bearing and to the crosshead areas that cycle through the linear bearings.
- ⇒ Check the packing regularly. If leakage is observed, stop the pump. Make a small adjustment by turning the gland nut. Restart the pump.
- ⇒ (Do not overtighten the packing as this will reduce the packing life and possibly damage the plunger.

It is always important to assure the packing material is compatible with the media being pumped—check for swollen or deteriorated seals.